



Instructions for the following series products:

Cobra Rope Grab Models:
AC202C, AC202C-SA2, AC202-SA3

USER INSTRUCTION MANUAL COBRA ROPE GRABS

This manual is intended to meet the Manufacturer’s Instructions as required by CSA Z259.2.5 and should be used as part of an employee training program.

WARNING: This product is part of a personal fall arrest or restraint system. The user must read and follow the manufacturer’s instructions for each component or part of the complete system. These instructions must be provided to the user of this equipment. The user must read and understand these instructions or have them explained to them before using this equipment. Manufacturer’s instructions must be followed for proper use and maintenance of this product. Alterations or misuse of this product or failure to follow instructions may result in serious injury or death.

IMPORTANT: If you have questions on the use, care, or suitability of this equipment for your application, contact Capital Safety.

IMPORTANT: Before using this equipment, record the product identification information from the ID label in the Inspection and Maintenance Log at the back of this manual.

DESCRIPTION:

The Protecta Cobra Rope Grab key components are depicted below in Figure 1. The Cobra Rope grab provides a portable lanyard connection point on a 5/8” diameter rope lifeline. The rope grab is designed to automatically follow the user and may be detached anywhere along the lifeline.

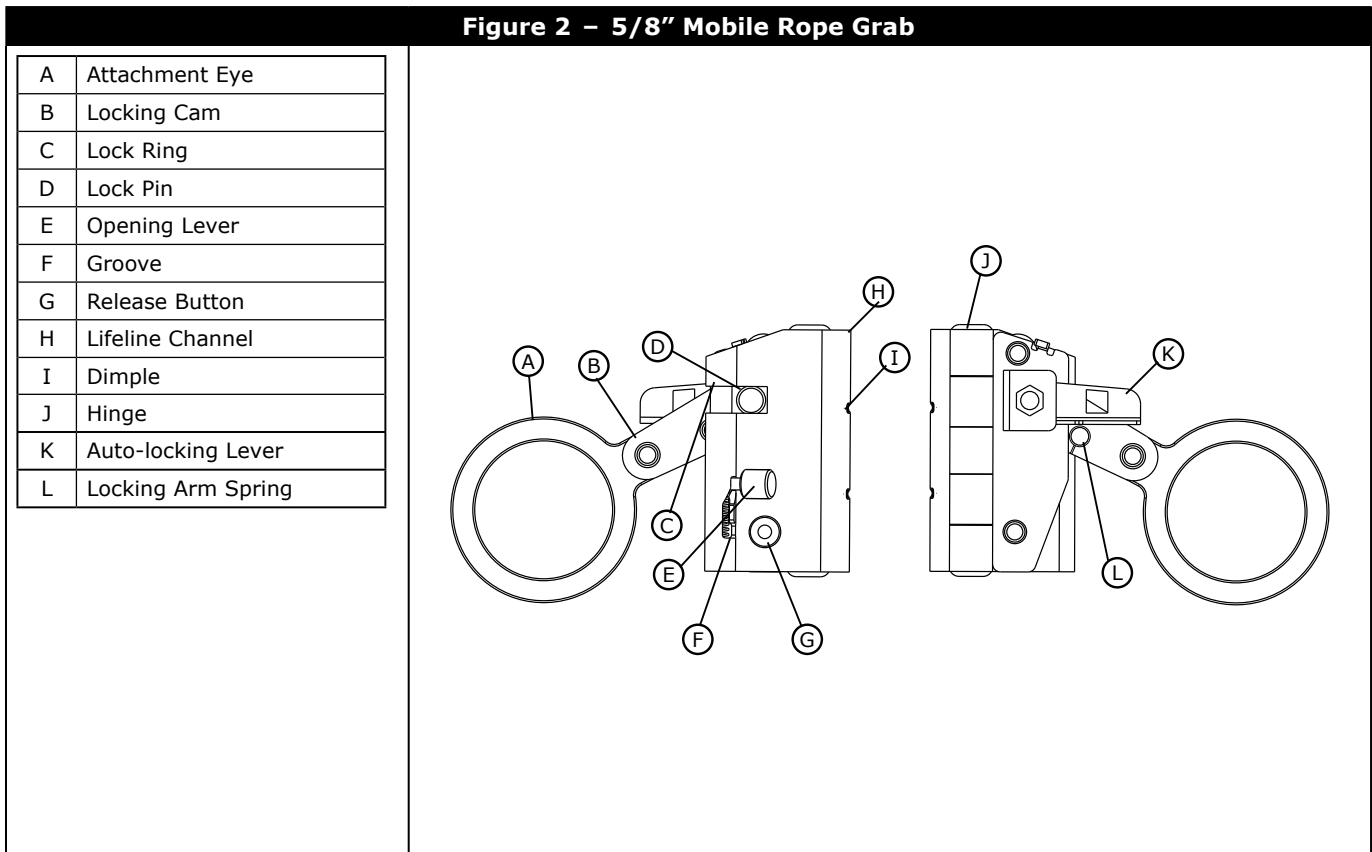

1.0 APPLICATION

1.1 PURPOSE: Protecta rope grab fall arresters are intended to be used as part of a personal fall arrest or restraint system. Applications for this type of product include inspection work, construction and demolition, maintenance, oil production, window washing, and other activities where there exists the need for fall arrest or restraint with vertical or sloped mobility. See Figures 2 & 3. The following definitions describe these applications:

A. FALL ARREST: The rope grab is used as part of a complete fall arrest system. Such systems generally include a lifeline, rope grab, energy absorbing lanyard, and full body harness (body support). Applications include: protection of a worker on scaffolding, powered platforms, or riding a boatswain's chair. Maximum permissible free fall is 1.8 m (5.9 feet). The rope grab must be used with an E4 energy absorbing lanyard less than .75 meter (30 inches) in length to meet CSA Z259.2.5 fall arrester requirements. Do not use rope grab without an energy absorber.

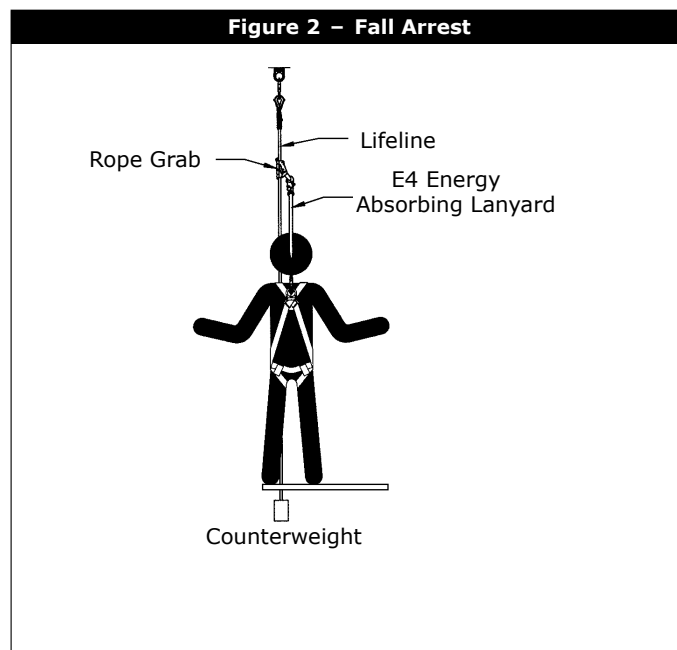

B. RESTRAINT: The rope grab is used in combination with a lifeline, lanyard or connector, and body support to restrain the user from reaching a hazard (sloped or leading edge roof work). No vertical free fall is possible.

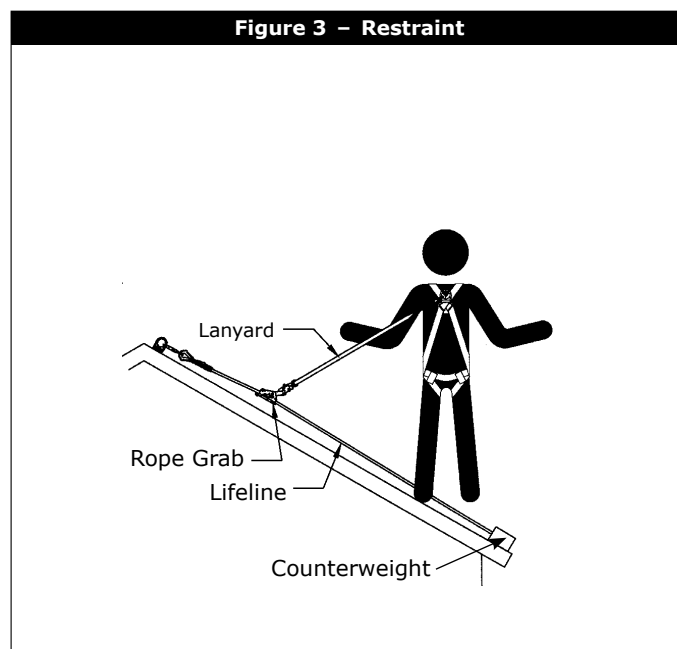

1.2 LIMITATIONS: Always consider the following limitations and requirements when installing or using this equipment:

- A. CAPACITY:** This equipment is designed for use by persons with a combined weight (person, clothing, tools, etc.) of no more than 115 Kg (254 lbs) when using an E4 energy absorbing lanyard. NOTE: No more than one person may be attached to a single lifeline.
- B. FREE FALL:** Restraint systems must be rigged such that there is no possible vertical free fall. Personal fall arrest systems must be used with an E4 energy absorbing lanyard and the system must be rigged to limit the free fall to 1.8 m (5.9 feet) or less per (CSA Z259.2.5). See associated connecting subsystem manufacturer's instructions for additional information.

- C. FALL CLEARANCE:** Make certain that enough clearance exists in your fall path to prevent striking an object. The amount of clearance required is dependent upon the type of connecting subsystem used (lanyard, lifeline), the anchorage location, and the amount of stretch in the lifeline, free fall distance and deceleration distance. See Section 3.2, Figure 7 for more information on determining fall clearance.
- D. CORROSION:** Do not leave this equipment for long periods in environments where corrosion of metal parts could take place as a result of vapors from organic materials. Sewage and fertilizer plants, for example, have high concentrations of ammonia. Use near seawater or other corrosive environments may require more frequent inspections or servicing to ensure corrosion damage is not affecting the performance of the product.
- E. CHEMICAL HAZARDS:** Solutions containing acids, alkali, or other caustic chemicals, especially at elevated temperatures, may cause damage to this equipment. When working with such chemicals, frequent inspection of this equipment must be performed. Consult DBI/SALA if doubt exists concerning using this equipment around chemical hazards.
- F. HEAT:** This equipment is not designed for use in high temperature environments. Protection should be provided for this equipment when used near welding, metal cutting, or similar activities. Hot sparks may burn or damage this equipment. Consult DBI/SALA for details on high temperature environments.
- G. ELECTRICAL HAZARDS:** Due to the possibility of electric current flowing through this equipment or connecting components, use extreme caution when working near high voltage power lines.
- H. COMPONENT COMPATIBILITY:** The rope grab addressed by these instructions is intended for use with DBI/SALA lifelines and lifeline subsystems only. Consult DBI/SALA if you are considering using this equipment with other lifelines or lifeline subsystems. See Section 2.0.
- I. TRAINING:** This equipment is to be used by persons who have been properly trained in its correct application and use.

1.3 REQUIREMENTS: Refer to applicable local, state, and federal requirements governing this equipment for more information on rope grabs and associated system components, including; CSA Z259.2.5.

1.4 RESCUE PLAN: When using this equipment, the employer must have a rescue plan and the means on hand to implement the rescue. The plan must also communicated to the plan users, authorized personnel and the rescuers as well.

1.5 INSPECTION BEFORE USE: The rope grab must be inspected according to procedures in Section 5 of this manual.

2.0 SYSTEM REQUIREMENTS

2.1 COMPATIBILITY OF COMPONENTS: Protecta equipment is designed for use with Protecta approved components and subsystems only. Substitutions or replacements made with non-approved components or subsystems may jeopardize compatibility of equipment and may effect the safety and reliability of the complete system.

2.2 COMPATIBILITY OF CONNECTORS: Connectors are considered to be compatible with connecting elements when they have been designed to work together in such a way that their sizes and shapes do not cause their gate mechanisms to inadvertently open regardless of how they become oriented. Contact Capital Safety if you have any questions about compatibility.

Connectors (hooks, carabiners, and D-rings) must be capable of supporting at least 22.2 kN (5,000 lbs.). Connectors must be compatible with the anchorage or other system components. Do not use equipment that is not compatible. Non-compatible connectors may unintentionally disengage. (See Figure 4). Connectors must be compatible in size, shape, and strength. If the connecting element to which a snap hook (shown) or carabiner attaches is undersized or irregular in shape, a situation could occur where the connecting element applies a force to the gate of the snap hook or carabiner. This force may cause the gate (of either a self-locking or a non-locking snap hook) to open, allowing the snap hook or carabiner to disengage from the connecting point. Self- locking snap hooks and carabiners are required.

Figure 4 – Unintentional Disengagement

If the connecting element to which a snap hook (shown) or carabiner attaches is undersized or irregular in shape, a situation could occur where the connecting element applies a force to the gate of the snap hook or carabiner. This force may cause the gate (of either a self-locking or a non-locking snap hook) to open, allowing the snap hook or carabiner to disengage from the connecting point.

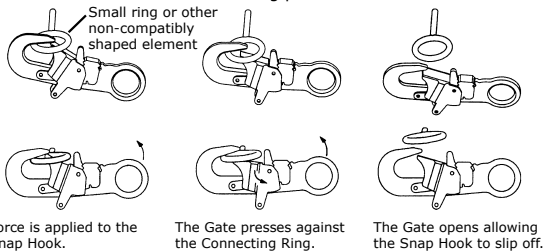
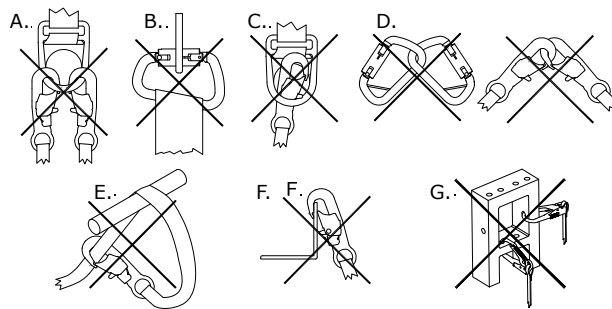

Figure 5 – Inappropriate Connections



2.3 MAKING CONNECTIONS: Use only self-locking snap hooks and carabiners with this equipment. Use only connectors that are suitable to each application. Ensure all connections are compatible in size, shape and strength. Do not use equipment that is not compatible. Ensure all connectors are fully closed and locked.

Protecta connectors (snap hooks and carabiners) are designed to be used only as specified in each product's user's instructions. See Figure 5 for inappropriate connections. Protecta snap hooks and carabiners should not be connected:

- A. To a D-ring to which another connector is attached.
- B. In a manner that would result in a load on the gate.

CAUTION: Large throat snap hooks should not be connected to standard size D-rings or similar objects which will result in a load on the gate if the hook or D-ring twists or rotates.

- C. In a false engagement, where features that protrude from the snap hook or carabiner catch on the anchor, and without visual confirmation seems to be fully engaged to the anchor point.
- D. To each other.
- E. Directly to webbing or rope lanyard or tie-back (unless the manufacturer's instructions for both the lanyard and connector specifically allows such a connection).
- F. To any object which is shaped or dimensioned such that the snap hook or carabiner will not close and lock, or that roll-out could occur.
- G. In a manner that does not allow the connector to align properly while under load.

2.4 ANCHORAGE STRENGTH: Anchorages selected for use with the rope grab must have a strength capable of sustaining the static load requirements of the intended fall protection application:

- A. **FALL ARREST:** Anchorages selected for fall arrest systems shall have a strength capable of sustaining static loads applied in the directions permitted by the system of at least:
 1. 22.2 kN (5,000 lbs) for non-certified anchorages, or
 2. Two times the maximum average arresting force for certified anchorages.

IMPORTANT: When more than one fall arrest system is attached to an anchorage, the strengths set forth in (1) and (2) above shall be multiplied by the number of systems attached to the anchorage.

WARNING: Tip-over anchors will have large anchor deformation that will affect system performance. This may also increase the required fall clearance below the system. This factor must be considered and it may be necessary to increase fall clearance in order to prevent serious injury or death to the user.

FROM OSHA 1926.500 AND 1910.66: Anchorages used for attachment of PFAS shall be independent of any anchorage being used to support or suspend platforms, and capable of supporting at least 22.2 kN (5,000 lbs) per user attached, or be designed, installed, and used as part of a complete PFAS which maintains a safety factor of at least two, and is supervised by a qualified person.

- B. **RESTRAINT:** Anchorages selected for restraint and travel restraint systems shall have a strength capable of sustaining static loads applied in the direction permitted by the system of at least:
 1. 4.5 kN (1,000 lbs) for non-certified anchorages, or
 2. Two times the foreseeable force for certified anchorages. When more than one restraint system is attached to an anchorage, the strength specified above shall be multiplied by the number of systems attached to the anchorage.

2.5 LIFELINE TERMINATION & COUNTERWEIGHT: AC202C Protecta rope grabs are to be used with protecta lifelines and lifeline subsystems. The lifeline used with the AC202C rope grabs is The lifeline certified for use with the AC202C rope grabs is the 5/8-inch (16mm) diameter rope made of polypropylene high modulus polyethylene Co-polymer. See appropriate lifeline instructions for more information and rope elongation factors. The following lifeline requirements must be follow:

- A. SIZE:** The rope grab is designed to be used only on 5/8-inch (16mm) diameter lifeline. Undersized rope may not allow the rope grab to lock properly and may cause excessive stopping distances. Oversized rope may impede rope grab mobility on the lifeline. It is recommended that lifeline diameter be 5/8 inch, ±1/32 inch (16mm ±0.8mm).
- B. CONSTRUCTION:** Three-strand lay rope constructions are required. Braided, double braided, hollow braided, or other types of rope constructions must not be used. When selecting the lifeline, choose a rope with a firm lay. Inspect the lay of the rope by grasping it several feet from the end between the thumb and index finger. You should not be able to easily squeeze or flatten the rope. Untwisting should be difficult and the rope should spring back to its original shape.
- C. MATERIAL:** The AC202C Rope Grab was certified to CSA Z259.2.5 on the following rope:

Lifeline Rope Material	Rope Part Number
Polypropylene High Modulus Polyethylene Co-polymer	9508057

- D. STRENGTH:** Select a lifeline which, when terminated and installed, will retain a minimum strength of (5,000 lbs.) 22kN per CSA Z259.2.5 Selection must account for strength reduction factors, such as sharp edges and degrading factors (i.e. chemicals).

IMPORTANT: CSA Z259.2.5 mandates the lower end of the lifeline have a termination that prevents the fall arrester from passing through that termination. When the line is installed, the bottom end shall also have a counterweight to provide stiffness. Knots shall not be used for load bearing end terminations.

2.6 CONNECTING LANYARD: The rope grab must be used with an E4 energy absorbing lanyard less than .75 m (30 inches) in length to meet CSA Z259.2.5 fall arrest requirements. All lanyards must have a minimum breaking strength of 22.2 kN (5,000 lbs).

2.7 BODY SUPPORT: The recommended body support for fall arrest applications is a full body harness, for restraint applications a body belt may be used.

IMPORTANT: Only lifeline ropes which meet the size, construction, and material properties required for compatible use with this rope grab may be used.

NOTE: Applications such as working near high voltage may require special lifeline materials, consult Protecta before using such lifelines.

3.0 OPERATION & USE

WARNING: Do not alter or intentionally misuse this equipment. Consult with Protecta if using this equipment with components or subsystems other than those described in this manual. Some subsystem and component combinations may interfere with the operation of this equipment.

WARNING: Do not use this equipment if you are unable to tolerate the impact from a fall arrest. Age and fitness can seriously affect your ability to withstand a fall. Pregnant women and minors must not use this equipment.

- 3.1 BEFORE EACH USE OF THIS EQUIPMENT,** carefully inspect it to ensure that it is in good working condition. See Section 5.0 for inspection details. Do not use if inspection reveals an unsafe condition.
- 3.2 PLAN** your fall arrest or restraint system before starting your work. Consider all factors that affect your safety before, during, and after a fall. Refer to these and related subsystem component instructions, and state and federal safety regulations for guidance in planning your system. The following list gives some important points to consider when planning your system:

- A. ANCHORAGE:** Select a rigid anchorage point that is capable of supporting the required loads. See Section 2.4. The anchorage location must be carefully selected to reduce possible free fall and swing fall hazards and to avoid striking an object during a fall. For restraint systems the anchorage must be located such that no vertical free fall is possible. For fall arrest systems OSHA requires the anchorage be independent of the means suspending or supporting the user.
- B. FREE FALL:** Do not work above the anchorage level, increased fall distance will result. Personal fall arrest systems must be rigged such that the potential free fall is never greater than 1.8 m (5.9 feet). Restraint systems must be rigged such that there is no possible vertical free fall.
- C. FALL ARREST FORCES:** The assembled fall arrest system must keep fall arrest forces below 4 kN (900 lbs) when used with a full body harness. Do not use a body belt for fall arrest.
- D. SWING FALLS:** Swing falls occur when the anchorage point is not directly above the point where a fall occurs. The force of striking an object while swinging can be great and cause serious injury. Swing falls can be minimized by working as directly below the anchorage as possible. See Figure 6.
- E. FALL CLEARANCE:** Make certain enough clearance exists in your fall path to prevent striking an object. The amount of clearance needed is dependent upon the type of connecting subsystem used and anchorage location. See Figure 7 for estimating fall clearance.
- Example - 1:** If the user has a Rope value 'A' of 15.2m (50 ft), the user will require a fall clearance of 6.2m (20.4 ft) with an E4 Energy Absorber. (See Figure 7.)
- F. SHARP EDGES:** Avoid working where parts of the system will be in contact with, or abrade against, unprotected sharp edges.
- G. RESCUE:** The user must have a rescue plan and the means at hand to implement it if a fall occurs.

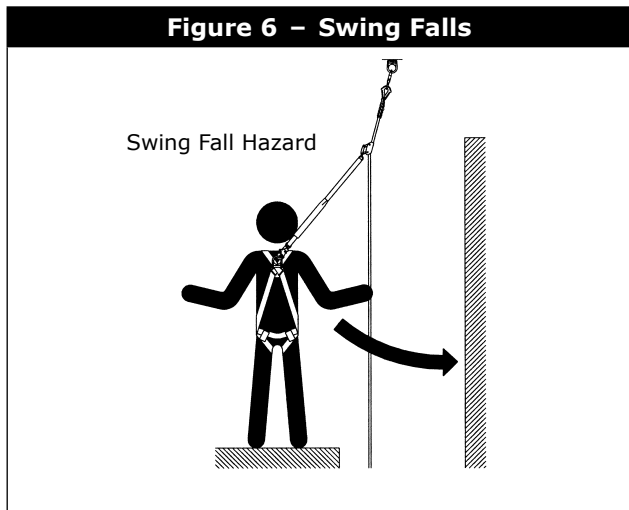

- H. **AFTER A FALL:** Components which have been subjected to the forces of arresting a fall must be removed from service immediately and destroyed.
- I. **GENERAL USE CONSIDERATIONS:** Avoid working where lifeline may cross or tangle with that of another worker. Do not allow the lanyard to pass under arms or between legs. Do not clamp, tie, or otherwise prevent the rope grab lanyard connection handle from moving freely into the "locked" position.
- J. **SLOPED ROOFS:** Provisions must be made (warning lines, monitors, guardrails) to prevent swing falls from unprotected roof edges or corners. The rope grab should be connected to the body support using a locking carabiner (direct connection) or a short lanyard. If a lanyard is used for connecting to the rope grab, keep the length as short as possible, and never greater than .75m (30 in). The lifeline must be protected from contact with sharp or abrasive edges and surfaces. The rope grab locking operation must not be hindered by interference with the roof or objects on the roof surface.

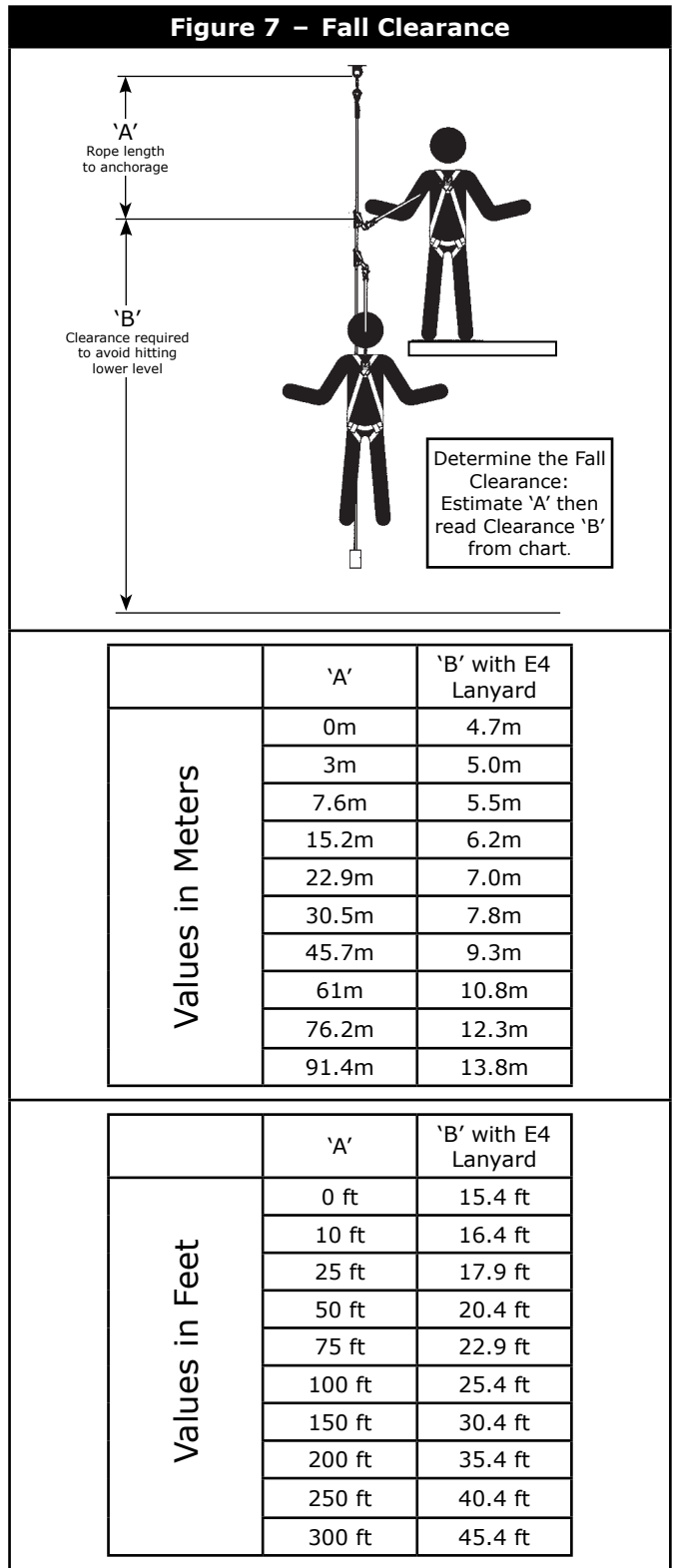

- K. **UNSTABLE SURFACES:** The rope grab is not suitable for use on unstable or slowly shifting materials, such as sand or grain.

3.3 ATTACHING THE COBRA ROPE GRAB TO THE LIFELINE:

IMPORTANT: For custom versions of this product, follow the instructions herein. If included, see supplemental instructions for additional information.

- A. Ensure the rope grab is in the 'UP' position as indicated on the product. The 'UP' end of the rope grab must be oriented towards the anchorage when installed onto the lifeline (see Figure 8). NOTE: Cobra rope grabs incorporate a gravity-lock pin that slides out of the locking pin to prevent the lifeline sleeve from mating with the rope grab cam when not held upright.
- B. Push the opening lever (knurled knob) downward until it reaches the bottom of the groove. Press the opening lever inward until the release button is completely depressed.
- C. Pull the lifeline sleeve and the locking cam apart until the unit is fully opened.
- D. To install on the lifeline, raise the locking cam to the "up" position and install the rope inside the lifeline channel and close the rope grab halves (see Figure 9). The spring-loaded lock pin will snap the unit shut.
- E. The closing action should release the opening lever from the open position and the locking pin will slide into the lock ring at the top of the lifeline sleeve. The opening lever should now be at the top of the groove and at rest against the lifeline sleeve (see Figure 10).
- F. Test the rope grab operation by pulling down on the locking cam. The rope grab must lock onto the lifeline and prevent any descent on the lifeline once the cam is engaged.

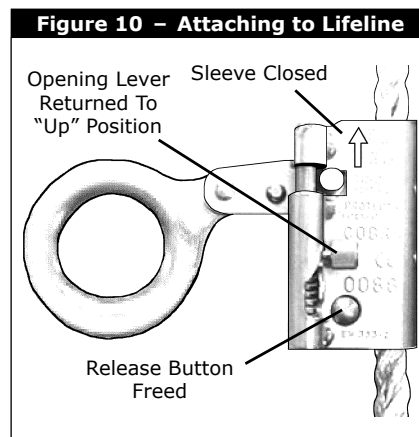
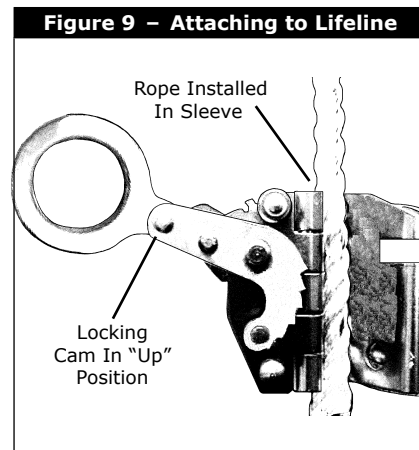
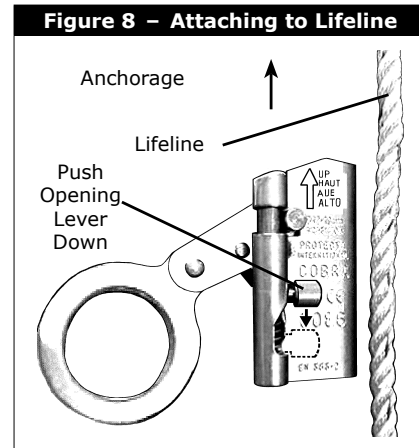

3.4 POSITIONING THE ROPE GRAB ON THE LIFELINE:

- A. Using the lanyard connected to the rope grab, pull up slightly on the rope grab to release it from its current position. Lift the handle if necessary. Keep a minimum of 4.7 m (15.4 ft) of rope below the rope grab for rope grab locking distance and fall clearance.
- B. Using the connected lanyard, raise or lower the rope grab to the desired new position. Tension the lifeline to assure smooth motion of the rope grab on the lifeline. To tension the lifeline, extend 15-22 m (50 to 75 feet) of lifeline below the rope grab, or secure the end of the lifeline at working or ground level, or use a six to ten pound counterweight. The method of tensioning used should be determined by job site conditions. NOTE: See Section 2.5 for recommendations and requirements.
- C. After moving the rope grab to a new position, position it at or above shoulder height to reduce possible free fall. Lock the rope grab at this position by pulling the lanyard connection handle to its full 'DOWN' position. The handle must be released before attempting to reposition the rope grab.
- D. Under special conditions, such as working on a moving platform, it is allowable to let the rope grab follow the worker as the platform is moved. The lanyard should be kept as short as possible and must not exceed .75 m (30 inches) in length.

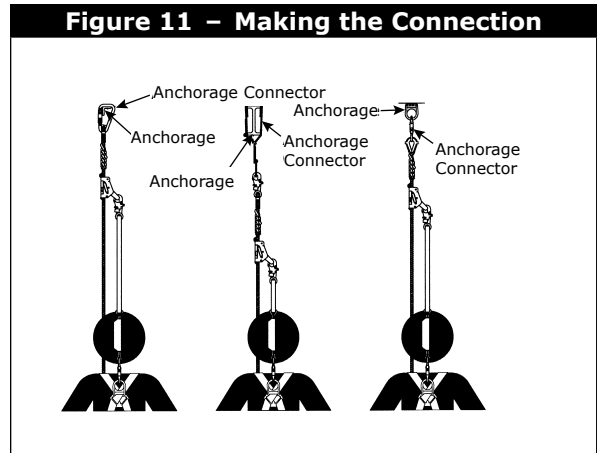

WARNING: Rope grab attachment and positioning instructions and procedures must be followed. Improper assembly could allow the rope grab to slip or not lock onto the lifeline in the event of a fall and may result in serious injury or death.

3.5 PARKING FEATURE:

- A. To activate the parking feature, release the lever from the tab on the side of the rope grab and allow it to rotate from vertical to horizontal. (See Figures 12 and 13.)
- B. The parking feature is now operational and will prevent the rope grab from traveling down the lifeline. This allows the user to remain on the lifeline for a period without the threat of the rope grab moving down the lifeline when the user is active. The rope grab operates in manual mode while the park feature is engaged.
- C. To deactivate the parking feature, return the auto-locking lever to upright, allowing the hole in the lever to catch on the tab on the side of the rope grab vertical position and unlock from the lifeline by lifting up on the locking cam.

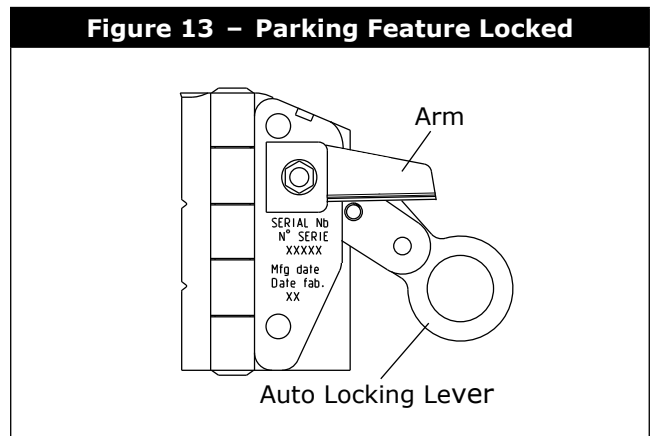
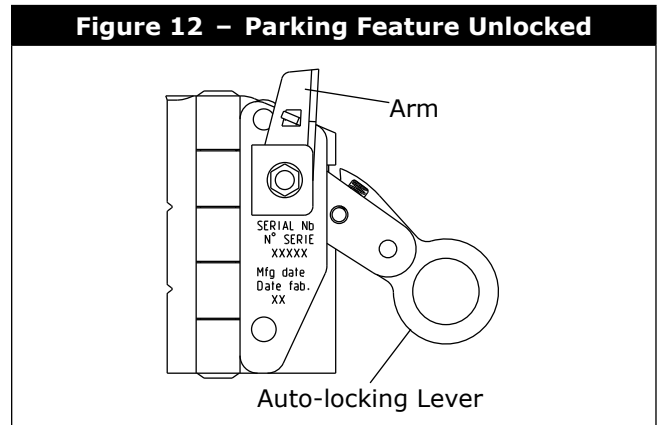

3.6 ANTI-PANIC GRIP FEATURE: The AC202C has an anti-panic grip feature. In the event of a fall, the user may grasp the rope grab in a manner that forces the locking cam into the open position. The Cobra rope grabs with the anti-panic grip feature have an additional cam in the center of the locking cam. This cam is pushed out and into the lifeline when the locking cam is forced beyond the open position, thus stopping a fall in spite of the locking cam being held in the open position.

3.7 CONNECTING TO ANCHORAGE OR ANCHORAGE CONNECTOR: When attaching the lifeline or lifeline subsystem to the anchorage or anchorage connector, ensure the connector (self-locking snap hook) is fully engaged and locked onto the connection point. Ensure connections are compatible in size, shape, and strength. Refer to the anchorage connector and lifeline manufacturer's instructions for further information. See Figure 14.

3.8 CONNECTING TO THE BODY SUPPORT: For fall arrest applications, connect to the dorsal D-ring located between the shoulders on the back of the full body harness. For restraint applications, the dorsal or frontal harness attachment may be used. If using a body belt for restraint applications connect to the D-ring opposite the restraining load. Ensure connections are compatible in size, shape, and strength. Refer to the body support manufacturer's instructions for more information on making connections. Under special conditions, such as working on a moving platform, it is allowable to let the rope grab follow the worker as the platform is moved. The lanyard should be kept as short as possible and must not exceed 0.75 m (30 inches) in length.

3.9 CONNECTING TO THE ROPE GRAB: When connecting an energy absorbing lanyard to the rope grab, attach the lanyard end (vs. the energy absorber end) to the rope grab to reduce possible interference with the operation of the rope grab by the energy absorber "pack". Some rope grab models may be supplied with a permanently attached lanyard or energy absorber. Do not attempt to attach additional lanyards or connectors to these subsystems. Ensure connections are compatible in size, shape, and strength. Ensure the connector attached to the rope grab allows the handle to rotate freely, and does not interfere with the rope grab operation.

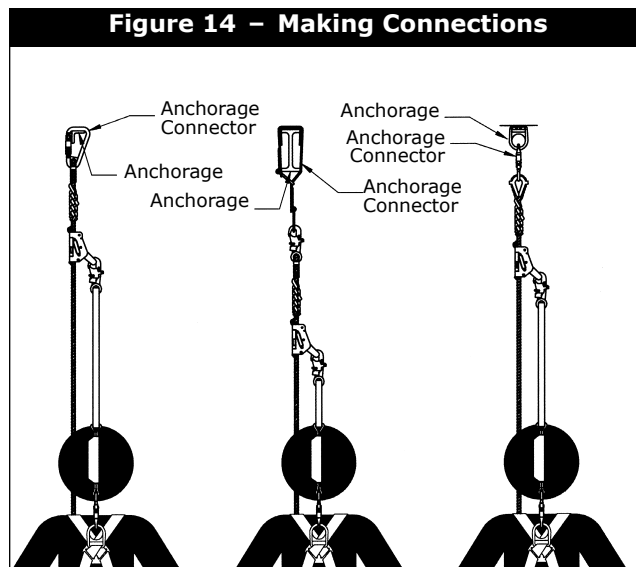

3.10 USE OF LIFELINES: (See Lifeline User Instruction Manual for complete details)

- Always protect the lifeline if passing over or around sharp edges. Sharp edges can reduce rope strength by 70% or more.
- Keep lifelines clean.
- Avoid twisting or kinking lifelines when coiling or uncoiling.
- Avoid using lifelines near acids or alkalines. If the lifeline is used around any chemical or compound, watch for signs of deterioration.
- Never use a knotted lifeline, knots can reduce rope strength by 50%.
- Always connect a counterweight to lifeline for stiffness, mandated per CSA Z259.2.5.
- Store lifelines properly. See Section 6.0.

3.11 AFTER USE of the rope grab and its subsystem components, return it for cleaning or storage as described in Section 6.0.

4.0 TRAINING

4.1 TRAINING: The user, and the user's employer, must be trained in the correct use and care of this equipment. Both parties must be aware of the operating characteristics, application limits, and consequences of improper use of this equipment.

IMPORTANT: Training must be conducted without exposing the trainee to a fall hazard. Training should be repeated on a periodic basis.

5.0 INSPECTION

5.1 FREQUENCY:

- A. Before Each Use,** visually inspect the equipment per steps listed in Sections 5.2, 5.3, and 5.4.
- B.** The rope grab must be inspected by a *competent person*¹ Section 1 other than the user at least annually. See Sections 5.2, 5.3, and 5.4 for guidelines. Record the results of each formal inspection in the inspection log found in back of manual.

IMPORTANT: If the rope grab has been subjected to fall arrest or impact forces, it must be immediately removed from service and destroyed.

IMPORTANT: Extreme working conditions (harsh environments, prolonged use, etc.) may require increasing the frequency of inspections.

5.2 INSPECTION STEPS FOR ROPE GRAB: See Figure 1.

- Step 1.** Inspect the attachment eye and locking cam to ensure that the cam moves freely without hesitation, binding or sticking.
- Step 2.** Inspect the locking cam and ensure that the teeth are not rounded or worn.
- Step 3.** Inspect the locking cam lever spring and auto-locking lever springs. Ensure they are in the proper location and undamaged.
- Step 4.** Inspect the spring for the locking pin (located in the groove) and ensure it is the proper location and undamaged.
- Step 5.** Use the opening lever (knurled knob) to ensure that the locking pin travels freely up and down the locking sleeve.
- Step 6.** Test repeatedly that the rope grab opens when the release button is depressed with the opening lever. The release button must be fully extended after the rope grab is closed.
- Step 7.** The two halves of the rope grab must close and open freely on the hinge. Inspect the lifeline channel and ensure that there are no dips or depressions worn into the channel and that the dimples are without damage. Ensure all the labels and engravings are legible.
- Step 8.** Inspect the hinge, attachment eye, and the rest of the rope grab for signs of corrosion, wear, cracks, distortion or other damage.
- Step 9.** With the rope grab open and upside-down, the gravity-lock pin should drop down and prevent the rope grab from closing
- Step 10.** Activate the parking feature and verify that there is resistance against the locking cam when attempting to raise the attachment eye. With the parking feature deactivated, there should be no resistance on the locking cam.
- Step 11.** To test models equipped with the Panic Lock feature, install rope grab on lifeline. Pass the thumb on one hand through the attachment eye and grasp the rope grab body with the rest of the hand. Force the eye to open the locking lever until it stops. Run the rope grab down the lifeline and ensure that it locks onto the lifeline.
- Step 12.** Record the inspection date and results in the inspection log in the back of the manual.

1 Competent Person: One who is capable of identifying existing and predictable hazards in the surroundings or working conditions which are unsanitary, hazardous, or dangerous to employees, and who has authorization to take prompt corrective measures to eliminate them.

5.3 INSPECTION STEPS FOR LIFELINE: (See the Lifeline User Instruction Manual for complete details)

- Step 1.** Lifeline hardware must not be damaged, broken, distorted, or have any sharp edges, burrs, cracks, worn parts, or corrosion. Ensure the connecting hooks work properly. Hook gates must move freely and lock upon closing.
- Step 2.** Inspect the rope for concentrated wear. The material must be free of frayed strands, broken yarns, cuts, abrasions, burns, and discoloration. The rope must be free of knots, excessive soiling, heavy paint buildup, and rust staining. Rope splices must be tight, with five full tucks, and thimbles must be held by the splice. Cracked or distorted rope thimbles may indicate that the lifeline has been impact loaded. Check for chemical or heat damage (indicated by brown, discolored, or brittle areas). Check for ultraviolet damage, indicated by discoloration and the presence of splinters and slivers on the rope surface. All of the above factors are known to reduce rope strength. Damaged or questionable ropes must be replaced.
- Step 3.** Inspect labels. All labels must be present and fully legible. Replace labels if illegible or missing
- Step 4.** Record the inspection date and results in the inspection log found in the Lifeline User Instruction Manual.

- 5.4** If an inspection reveals a defective condition, remove the unit from service immediately and destroy, or contact a factory authorized service center for repair.

IMPORTANT: Do not attempt to alter, repair, or make substitutions to the rope grab or rope grab parts. Equipment found to be in defective condition must be removed from service. Repairs may only be performed by Protecta or those authorized in writing to do so.

6.0 MAINTENANCE

- 6.1** Clean the rope grab and lifeline with water and a mild soap solution. Wipe off hardware with a clean, dry cloth, and hang to air dry. Do not force dry with heat. An excessive buildup of dirt, paint, etc. may prevent the rope grab or lifeline from working properly, and in severe cases degrade the rope grab or rope to a point where it has weakened and should be removed from service. If you have any questions concerning the condition of the rope grab or lifeline, or have any doubt about putting them into service, contact Protecta. See the Lifeline User Instruction Manual for specific maintenance details.
- 6.2** Additional maintenance and servicing procedures (replacement parts) must be completed by a factory authorized service center. Authorization must be in writing. Do not attempt to disassemble the unit. See Section 5.1 for inspection frequency.
- 6.3** Store the rope grab and lifeline in a cool, dry, clean environment out of direct sunlight. Avoid areas where chemical vapors may exist. Thoroughly inspect the rope grab and lifeline after any period of extended storage.

7.0 SPECIFICATIONS / PERFORMANCE DATA

7.1 SPECIFICATIONS:

Material: All material used in construction is certified to be new and free from defects.

Construction: Riveted and welded with hinged rope channel.

Material Type: Body, hinge, cam, and attachment eye – High impact resistant steel

Weight: 0.8 kgs (1.75 lbs)

Lifeline Diameter: 16mm (5/8 inch)

Parking Feature: Allows manual operation as required

Patent Number: U.S. 4,657,110, Can. 1,241,937, U.K. GB2,168,102B

7.2 PERFORMANCE DATA:

- **Arrest Force:** Designed for 4 kN (900 lbs) maximum arresting force with an E4 energy absorbing lanyard.
- **Maximum Capacity:** 115 kg (254 lbs) when using an E4 Energy Absorbing Lanyard.
- **Requirements:** Meets applicable local and federal standards.

8.0 MARKINGS

8.1 These labels and/or markings must be securely attached and fully legible:

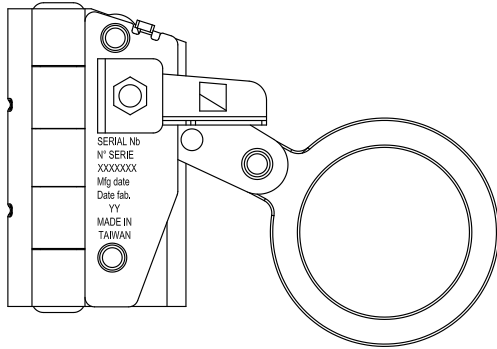

AC202C COBRA MARKINGS

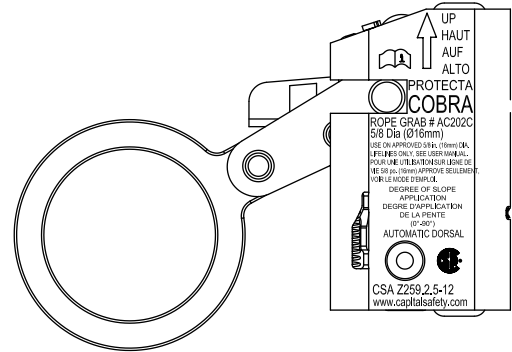

AC202C COBRA MARKINGS

LIMITED LIFETIME WARRANTY

Warranty to End User: D B Industries, LLC dba CAPITAL SAFETY USA ("CAPITAL SAFETY") warrants to the original end user ("End User") that its products are free from defects in materials and workmanship under normal use and service. This warranty extends for the lifetime of the product from the date the product is purchased by the End User, in new and unused condition, from a CAPITAL SAFETY authorized distributor. CAPITAL SAFETY'S entire liability to End User and End User's exclusive remedy under this warranty is limited to the repair or replacement in kind of any defective product within its lifetime (as CAPITAL SAFETY in its sole discretion determines and deems appropriate). No oral or written information or advice given by CAPITAL SAFETY, its distributors, directors, officers, agents or employees shall create any different or additional warranties or in any way increase the scope of this warranty. CAPITAL SAFETY will not accept liability for defects that are the result of product abuse, misuse, alteration or modification, or for defects that are due to a failure to install, maintain, or use the product in accordance with the manufacturer's instructions.

CAPITAL SAFETY'S WARRANTY APPLIES ONLY TO THE END USER. THIS WARRANTY IS THE ONLY WARRANTY APPLICABLE TO OUR PRODUCTS AND IS IN LIEU OF ALL OTHER WARRANTIES AND LIABILITIES, EXPRESSED OR IMPLIED. CAPITAL SAFETY EXPRESSLY EXCLUDES AND DISCLAIMS ANY IMPLIED WARRANTIES OF MERCHANTABILITY OR FITNESS FOR A PARTICULAR PURPOSE, AND SHALL NOT BE LIABLE FOR INCIDENTAL, PUNITIVE OR CONSEQUENTIAL DAMAGES OF ANY NATURE, INCLUDING WITHOUT LIMITATION, LOST PROFITS, REVENUES, OR PRODUCTIVITY, OR FOR BODILY INJURY OR DEATH OR LOSS OR DAMAGE TO PROPERTY, UNDER ANY THEORY OF LIABILITY, INCLUDING WITHOUT LIMITATION, CONTRACT, WARRANTY, STRICT LIABILITY, TORT (INCLUDING NEGLIGENCE) OR OTHER LEGAL OR EQUITABLE THEORY.



Global Leader in Fall Protection

USA

3833 SALA Way
Red Wing, MN 55066-5005
Toll Free: 800.328.6146
Phone: 651.388.8282
Fax: 651.388.5065
solutions@capitalsafety.com

Brazil

Rua Anne Frank, 2621
Boqueirão Curitiba PR
81650-020
Brazil
Phone: 0800-942-2300
brasil@capitalsafety.com

Mexico

Calle Norte 35, 895-E
Col. Industrial Vallejo
C.P. 02300 Azcapotzalco
Mexico D.F.
Phone: (55) 57194820
mexico@capitalsafety.com

Colombia

Compañía Latinoamericana de Seguridad S.A.S.
Carrera 106 #15-25 Interior 105 Manzana 15
Zona Franca - Bogotá, Colombia
Phone: 57 1 6014777
servicioalcliente@capitalsafety.com

Canada

260 Export Boulevard
Mississauga, ON L5S 1Y9
Phone: 905.795.9333
Toll-Free: 800.387.7484
Fax: 888.387.7484
info.ca@capitalsafety.com

EMEA (Europe, Middle East, Africa)

EMEA Headquarters:
5a Merse Road
North Moons Moat
Redditch, Worcestershire
B98 9HL UK
Phone: + 44 (0)1527 548 000
Fax: + 44 (0)1527 591 000
csgne@capitalsafety.com

France:

Le Broc Center
Z.I. 1re Avenue - BP15
06511 Carros Le Broc Cedex
France
Phone: + 33 04 97 10 00 10
Fax: + 33 04 93 08 79 70
information@capitalsafety.com

Australia & New Zealand

95 Derby Street
Silverwater
Sydney NSW 2128
Australia
Phone: +(61) 2 8753 7600
Toll-Free : 1800 245 002 (AUS)
Toll-Free : 0800 212 505 (NZ)
Fax: +(61) 2 8753 7603
sales@capitalsafety.com.au

Asia

Singapore:
69, Ubi Road 1, #05-20
Oxley Bizhub
Singapore 408731
Phone: +65 - 65587758
Fax: +65 - 65587058
inquiry@capitalsafety.com

Shanghai:

Rm 1406, China Venturetech Plaza
819 Nan Jing Xi Rd,
Shanghai 200041, P R China
Phone: +86 21 62539050
Fax: +86 21 62539060
inquiry@capitalsafety.cn

www.capitalsafety.com

